

**AMERICAN COOLING TECHNOLOGY, Inc.**

# ADVANCED BUS AIR CONDITIONING



## CR-2 CONDENSER

THE A.C.T. **CR-2** CONDENSER IS DESIGNED FOR ROOF MOUNT APPLICATIONS. WE HAVE MANUFACTURED THIS UNIT TO OFFER OUR CUSTOMERS GREATER FLEXIBILITY IN CONDENSER PLACEMENT.

IT'S LOW PROFILE, LIGHT WEIGHT ALUMINUM STRUCTURE, (TOTAL WEIGHT ONLY 37 LBS.), ENHANCED AIR FLOW, PERFORMANCE, SERVICABILITY, AND INSTALLATION EASE ARE THE RESULT OF MANY YEARS OF EXPERIENCE IN THIS INDUSTRY.



### ADVANCED FEATURES

- Powder Coated White
- Highgrade, Lightweight, Rust Proof Aluminum
- Internally Enhanced Rifled Copper Tubing Increases System Performance
- Unequalled Heat Rejection....
  - Lower Cooling Temperatures
  - Lower Head Pressures
- No External Fittings
- 12 Inch Diameter Fan For Increased Airflow
- Sealed Motor Design
- Sealed Electrical Connections

### OPTIONS

- Optional Mounting Rails for Curved or Flat-top Roofs
- Tubular Aluminum Brush Guard
- Optional 30 Cu. In. Filter Drier
- 12 Volt or 24 Volt Motors
- Winter Protection Kit

**2 YEAR  
LIMITED WARRANTY**

**AMERICAN COOLING TECHNOLOGY, Inc.**

715 Willow Springs Lane, York, PA 17406  
Tel:717-767-2775 Fax:717-767-3658  
www.americancoolingtechnology.com

**Toll Free: 877-228-4247**



### SPECIFICATIONS

**RATING: 60,000 Btu/Hr (15,120 kcal)**

**AIRFLOW: 1850 cfm (3136 m<sup>3</sup>/hr)**

**AMPERAGE DRAW: 23@ 13.5 Volts**

**11@ 27 Volts**

**CONDENSER FANS: 12 Inch Diameter,  
Sealed Motor**

**FILTER DRIER/SIGHTGLASS: 16 Cu. Inch  
Displacement w/Moisture Indicator**

**WEIGHT: 37 lbs.**

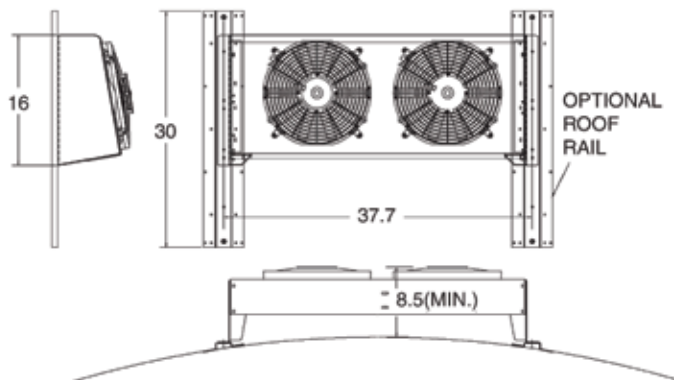

**RELY ON OUR EXPERIENCE TO PROPERLY APPLY YOUR BUS AIR CONDITIONING SYSTEM**